

APPROVALS



ENGINEERING CODE
943CA11

APPROVED REFRIGERANT
R-404A

POWER SUPPLY
220-240 V 50 Hz

STANDARD CONDITIONS
ASHRAE

APPLICATION
LBP

COOLING CAPACITY
1196 W

EFFICIENCY
1.26 W/W

MOTOR TYPE
CSCR

STARTING TORQUE
HST

DATA

General Data

Type	Hermetic reciprocating
Technology Type	On-Off
Displacement	26.1 cm ³
Compressor Cooling	Fan
Fan Air Flow	800 m ³ /h
Expansion Device	Capillary Tube or Expansion Valve
Horse Power	1 1/4 hp
Max Condensing Pressure Operating	24.71 bar
Max Condensing Pressure Peak	27.71 bar
Power Supply	220-240 V 50 Hz
Evaporating Temperature Range	-40 °C to -10 °C

Electrical Data

Motor type	CSCR
Starting Torque	HST
Start Winding Resistance	7.43 Ω at 25° C
Run Winding Resistance	1.92 Ω at 25° C

Mechanical Data

Maximum Recommended Refrigerant Charge	800 g
Oil Charge	750 ml
Oil Type Configuration	Polyolester
Oil Type Viscosity	ISO22
Pressurization	Dry air charge
Weight	22 Kg
Free Internal Volume	3.9 L

Electrical Components

	Description
CSR / CSIR Box	yes
Motor Protection	Internal 15HM1962
Start Capacitor	88-108 ?F / 330V
Starting Device	Potential relay RVA2L3C-112

External Characteristics

Base Plate	Large	
Tray Holder	No	
Height	276 mm	
Connector	Internal Diameter	Shape
Suction	12.77 mm	Vertical
Discharge	8 mm	Slanted 65°
Process	6.42 mm	Vertical

PERFORMANCE

Rated Points

Condensing Temperature	Evaporating Temperature	Cooling Capacity	Power Consumption	Current	Gas Flow Rate	Efficiency
54.40°C	-23.30°C	1196 W	951 W	5.08 A	27.65 kg/h	1.26 W/W

Test Condition: ASHRAE, Fan, Return Gas 32.2°C, Evaporation -23.30°C, Condensing 54.40°C, Ambient 32.2°C, Liquid 32.2°C. Data in accordance to ASHRAE guideline polynomial curve.

Performance Curve Data

Condensing Temperature 35°C

Evaporating Temperature °C	Cooling Capacity W	Power W	Current A	Gas Flow Rate kg/h	Efficiency W/W
-40	564	544	3.49	12.90	1.04
-35	741	629	3.8	17.01	1.18
-30	982	721	4.15	22.65	1.36
-25	1287	819	4.55	29.82	1.57
-20	1655	923	4.99	38.56	1.79
-15	2085	1032	5.46	48.90	2.02
-10	2578	1146	5.97	60.85	2.25

Test Condition: ASHRAE, Fan, LBP. Data in accordance to ASHRAE guideline polynomial curve.

Condensing Temperature 45°C

Evaporating Temperature °C	Cooling Capacity W	Power W	Current A	Gas Flow Rate kg/h	Efficiency W/W
-35	640	632	3.8	14.68	1.01
-30	880	744	4.23	20.25	1.18
-25	1173	860	4.7	27.12	1.36
-20	1519	979	5.21	35.31	1.55
-15	1916	1101	5.74	44.84	1.74
-10	2366	1224	6.31	55.74	1.93

Test Condition: ASHRAE, Fan, LBP. Data in accordance to ASHRAE guideline polynomial curve.

Condensing Temperature 55°C

Evaporating Temperature °C	Cooling Capacity W	Power W	Current A	Gas Flow Rate kg/h	Efficiency W/W
-30	797	773	4.35	18.32	1.03
-25	1084	909	4.9	25.01	1.19
-20	1413	1045	5.48	32.78	1.35
-15	1784	1181	6.09	41.65	1.51
-10	2196	1317	6.72	51.64	1.67

Test Condition: ASHRAE, Fan, LBP. Data in accordance to ASHRAE guideline polynomial curve.

Operating Envelope

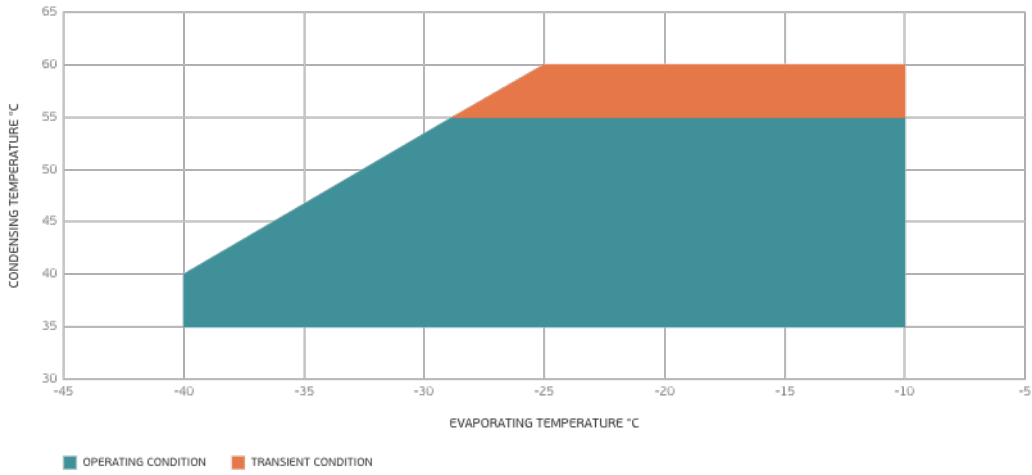

External Dimensions

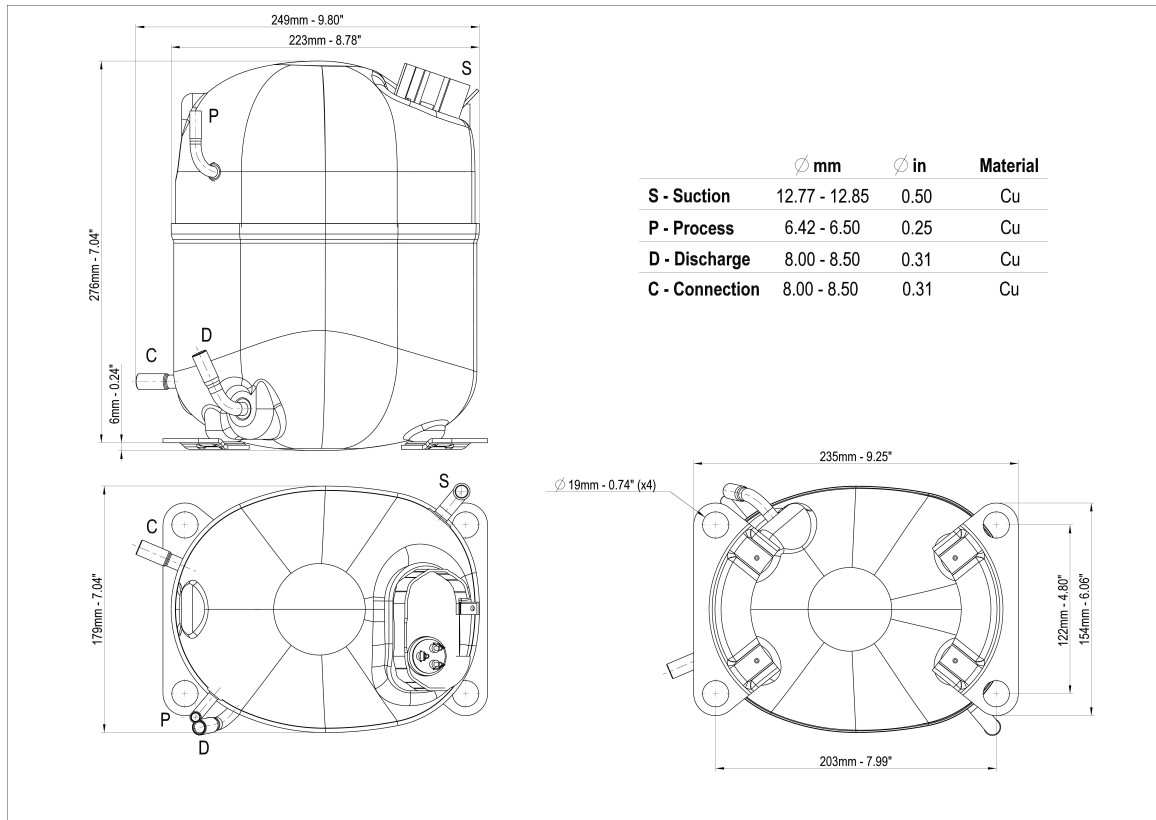

Wiring Diagram

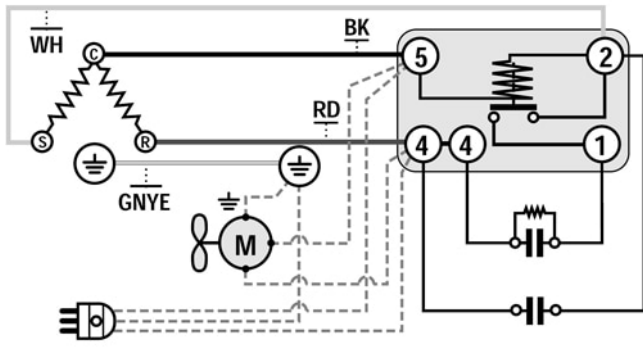

Assembly Instructions

